

NOT RECOMMENDED FOR NEW DESIGNS

Contact Linear Technology for Potential Replacement

FEATURES

- Complete Battery Backup System in an SO-8, 16-Pin GN or SO Package
- Generates Adjustable Backup Voltage from a Single 1.2V NiCd Button Cell
- Automatic Main Supply to Backup Switching
- Minimum 100mW Output Power
- Automatic Fast Recharge of NiCd Battery
- Programmable NiCd Trickle Charge Current
- Smart NiCd Charger Minimizes Recharge Time and Maximizes System Efficiency After Backup
- On-Chip Power-On Reset
- Pushbutton Reset Input
- Reset Assertion Guaranteed at $V_{CC} = 1V$
- Short-Circuit Protection
- Thermal Limiting

APPLICATIONS

- Notebook Computers
- Palmtop Computers/PDAs
- Portable Instruments
- Battery-Powered Systems

DESCRIPTION

The LTC[®]1558 is a backup battery controller that provides all the functions necessary to implement a backup power supply using a single NiCd cell. It includes a 1.2V boost converter, an intelligent 2-stage battery charger, automatic backup switching and a microprocessor reset generator. The boost converter uses a synchronous switching architecture to achieve a typical efficiency of 70%, ensuring maximum backup lifetime from a small NiCd cell.

The on-chip NiCd charger uses an internal gas gauge to minimize fast recharge time and prevent overcharging of the backup cell. The LTC1558 also provides a user programmable trickle charge current to compensate for self discharge losses in the backup cell.

The LTC1558's automatic backup switching architecture requires minimum intervention from the host system and provides feedback to the host to minimize system loading in the backup state. Its internal V_{CC} fault detector and reset generator eliminate the need for a separate microprocessor supervisory chip in most applications.

The LTC1558 is available in an SO-8, 16-lead GN or SO package.

LT, LTC and LT are registered trademarks of Linear Technology Corporation.

TYPICAL APPLICATION

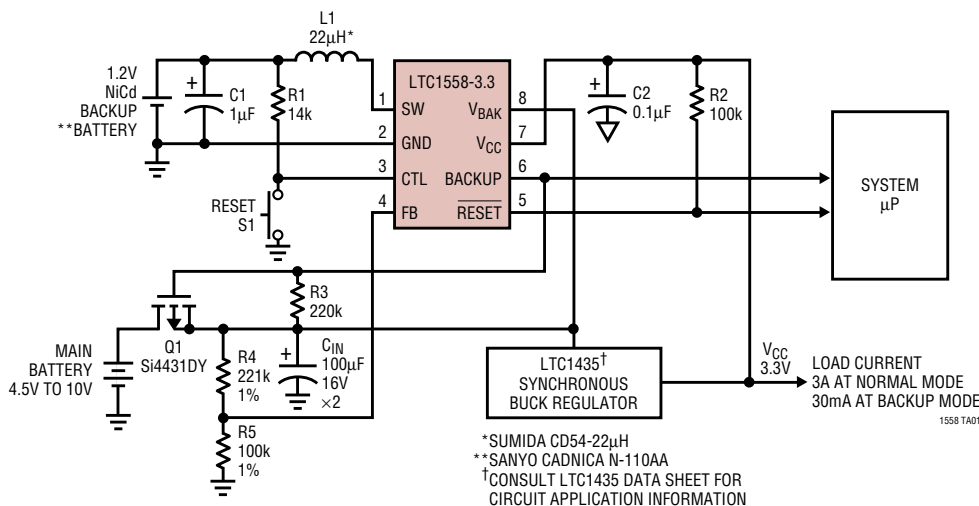

Backup Time
 vs 3.3V Output Load Current

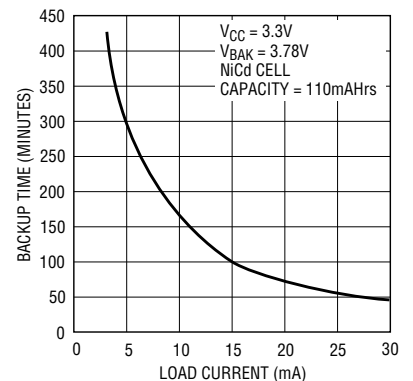

LTC1558-3.3/LTC1558-5

ABSOLUTE MAXIMUM RATINGS

(Note 1)

Terminal Voltages

V_{CC}	6V
V_{BAK} , BACKUP	12V
SW	14V
All Other Pins	-0.3V to $V_{CC} + 0.3V$
Input Currents (SW)	500mA

V_{BAK} Output Current	Short-Circuit Protected
Operating Ambient Temperature Range	0°C to 70°C
Junction Temperature	125°C
Storage Temperature Range	-65°C to 150°C
Lead Temperature (Soldering, 10 sec)	300°C

PACKAGE/ORDER INFORMATION

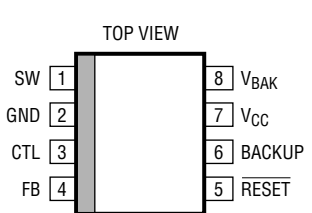
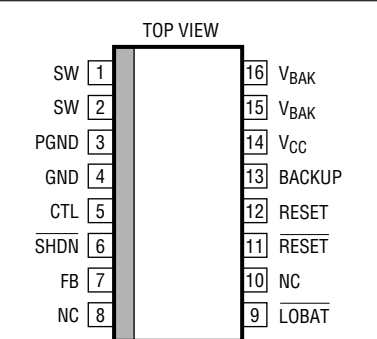
 <p>TOP VIEW</p> <p>SW 1, GND 2, CTL 3, FB 4, V_{BAK} 8, V_{CC} 7, BACKUP 6, RESET 5</p> <p>S8 PACKAGE 8-LEAD PLASTIC SO T_{JMAX} = 125°C, θ_{JA} = 130°C/W</p>	ORDER PART NUMBER	 <p>TOP VIEW</p> <p>SW 1, SW 2, PGND 3, GND 4, CTL 5, SHDN 6, FB 7, NC 8, V_{BAK} 16, V_{BAK} 15, V_{CC} 14, BACKUP 13, RESET 12, RESET 11, NC 10, LOBAT 9</p> <p>GN PACKAGE 16-LEAD PLASTIC SSOP T_{JMAX} = 125°C, θ_{JA} = 110°C/W (GN) T_{JMAX} = 125°C, θ_{JA} = 110°C/W (S)</p> <p>S PACKAGE 16-LEAD PLASTIC SO</p>	ORDER PART NUMBER
	LTC1558CS8-3.3 LTC1558CS8-5		LTC1558CGN-3.3 LTC1558CGN-5 LTC1558CS-3.3 LTC1558CS-5
	S8 PART MARKING		
	155833 15585		

Consult factory for Industrial and Military grade parts.

ELECTRICAL CHARACTERISTICS $V_{BAT} = 1.2V$, $T_A = 0^\circ C$ to $70^\circ C$ unless otherwise noted.

SYMBOL	PARAMETER	CONDITIONS	MIN	TYP	MAX	UNITS	
Battery Backup Switching							
V_{CC}	Operating Voltage Range	LTC1558-3.3 LTC1558-5	● ●	2.90 4.40	3.465 5.250	V V	
V_{BAT}	Backup Battery Cell Voltage		●	1.0	1.2	1.5	V
V_{REF}	Internal Reference Voltage		●	1.247	1.272	1.297	V
I_{VCC}	Quiescent Supply Current (Note 2)		●	155	250	μA	
I_{BAT}	Peak Inductor Current (Backup Mode)	Boost Converter in Low Current Mode (Note 7) Boost Converter in High Current Mode (Note 7)	● ●	80 225	165 330	225 445	mA mA
$I_{BAT(SHDN)}$	Battery Standby Current	$V_{CC} = 0V$	●	0.1	15	μA	
$I_{VCC(SHDN)}$	Supply Current During Shutdown (Note 3)		●		50	μA	
$V_{BAK(ON)}$	Backup Request Trip Point	Voltage at V_{FB} Relative to V_{REF}	●	-10.5	-7.5	-5.5	%
$V_{BST(ON)}$	Boost Converter Assertion Trip Point	Voltage at V_{FB} Relative to V_{REF}	●	-10.5	-7.5	-5.5	%
$V_{BAK(OFF)}$	Backup Deassertion Trip Point	Voltage at V_{FB} Relative to V_{REF}	●	-9	-6	-4	%
$V_{BST(OFF)}$	Boost Converter Deassertion Trip Point	Voltage at V_{FB} Relative to V_{REF}	●	-10.5	-7.5	-5.5	%
V_{LOBAT}	Low V_{BAT} Detect (Note 3)		●	0.95	1	1.05	V

ELECTRICAL CHARACTERISTICS

$V_{BAT} = 1.2V$, $T_A = 0^{\circ}C$ to $70^{\circ}C$ unless otherwise noted.

SYMBOL	PARAMETER	CONDITIONS	MIN	TYP	MAX	UNITS
$V_{UVLO(ON)}$	V_{CC} UVLO Trip Voltage (Note 4)	LTC1558-3.3	● 2.90	3.00	3.10	V
		LTC1558-5	● 4.40	4.55	4.70	V
$V_{UVLO(OFF)}$	V_{CC} UVLO Recovery Trip Voltage (Note 4)	LTC1558-3.3	● 3.00	3.10	3.20	V
		LTC1558-5	● 4.55	4.70	4.85	V
V_{LOBAT}	V_{BAT} UVLO Trip Voltage (Note 5)		● 0.85	0.9	0.95	V

Backup Battery Charger

I_{CHGF}	Battery Charge Current	Fast Recharge	●	11	16	21	mA
I_{CHGT}	Programmable Trickle Charge Current Range			0.05		2	mA
Q_{RECH}	Fast Recharge Factor (Note 6)			1.35	1.6	1.85	C/C
Q_{TRK}	Nominal Trickle Charge Multiplier Factor	$I_{CHGT} = 1mA$		8	10	12	A/A
$V_{CTL(CLAMP)}$	Trickle Charge Clamp Voltage	$I_{CHGT} = 1mA$	●	0.45	0.5	0.55	V

Pushbutton Reset

V_{CTL}	CTL Input Threshold					250	mV
t_{CTL}	CTL Input Low Time (Debounce Time)			20			ms

Reset Timer

t_{HRESET}	Pushbutton Duration for Hard Reset			1.10	1.8	3.4	s
t_{RST}	RESET Pulse Width	V_{CTL} Low for $< t_{HRESET}$ (Soft Reset)	●	50	80	150	μs
		V_{CTL} Low for $> t_{HRESET}$ (Hard Reset)	●	115	185	345	ms
V_{RST1}	RESET Output Voltage	$V_{CC} = 1V$, $I_{SINK} = 10\mu A$	●		5	200	mV
V_{RST}	RESET Output Voltage	$V_{CC} = 4.25V$, $I_{SINK} = 1.6mA$	●		0.1	0.4	V
I_{SC}	RESET Output Current	Output Source Current, $V_{CC} = 3.3V$			10		mA
		Output Source Current, $V_{CC} = 5V$			20		mA
	Short-Circuit Current	Output Sink Current, $V_{CC} = 3.3V$			20		mA
		Output Sink Current, $V_{CC} = 5V$			40		mA

Internal V_{CC} Monitor Comparator

t_{PLH}	$V_{UVLO(ON)}$ Comparator Propagation Delay (Rising)	$\Delta V_{CC} = -(9\% V_{CC} + 300mV)$, $V_{OD} = 300mV$			9		μs
-----------	--	--	--	--	---	--	---------

Shutdown Pin (Note 3)

V_{SHDN}	SHDN Input Threshold	Logic Low, V_{IL} Logic High, V_{IH}	● ●			0.8	V V
I_{SHDN}	SHDN Pin Bias Current	$V_{CC} = 5V$, $V_{SHDN} = 0V$	●		8	15	μA

Feedback Pin

I_{FB}	FB Pin Bias Current				1	10	nA
----------	---------------------	--	--	--	---	----	----

The ● denotes specifications which apply over the full operating temperature range.

Note 1: Absolute Maximum Ratings are those values beyond which the life of a device may be impaired.

Note 2: Quiescent current is measured during pushbutton reset.

Note 3: Only applies to 16-pin version.

Note 4: Thresholds will track each other and are guaranteed not to overlap.

Note 5: Low cell voltage reset is only triggered when $0.25V < V_{CTL} < 0.9V$ for at least $20\mu s$ while in backup mode.

Note 6: Fast recharge factor is defined as the ratio of charge replenished to the NiCd battery during fast recharge to the charge drawn from the NiCd battery during backup.

Note 7: The LTC1558 switches automatically between the low and high operating current levels. See Applications Information for more details.

TYPICAL PERFORMANCE CHARACTERISTICS

Output Power vs Battery Voltage

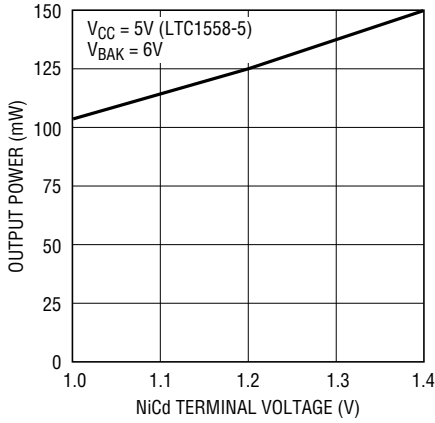

1558 G01

Backup Time vs Battery Capacity

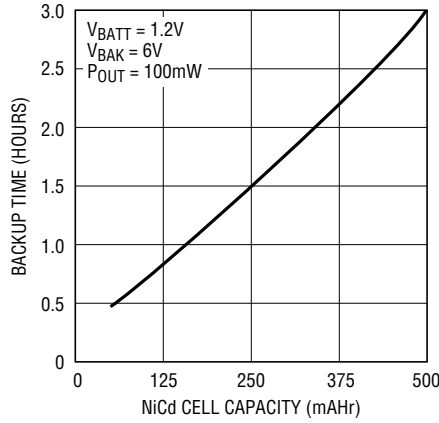

1558 G02

Boost Converter Switching Frequency

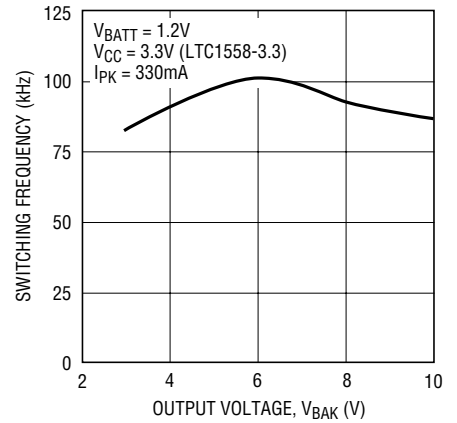

1558 G03

Boost Converter Switching Duty Cycle

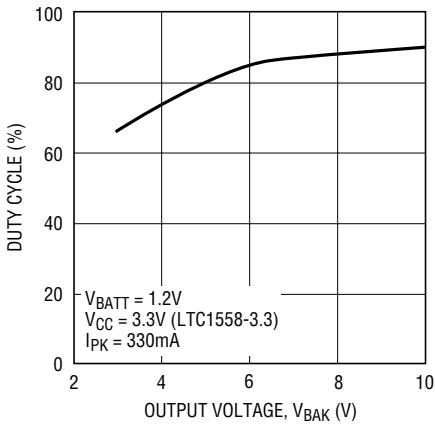

1558 G04

Trickle Charge Multiplier Factor

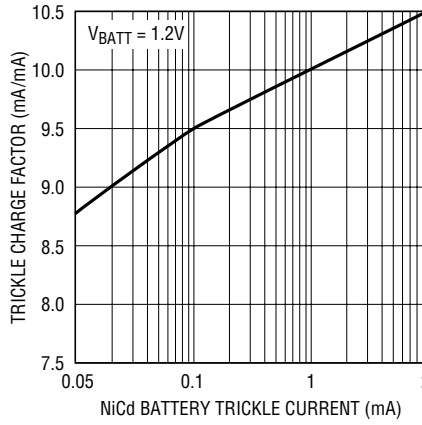

1558 G05

Normalized Fast Recharge Current vs Temperature

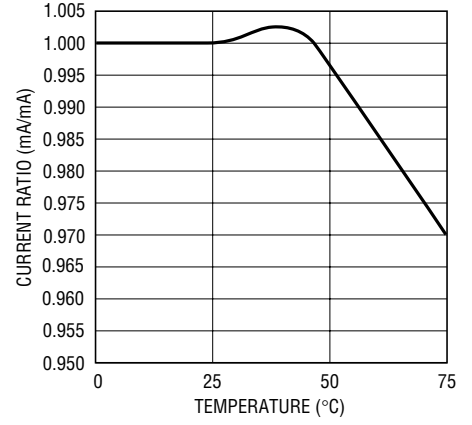

1558 G06

Fast Recharge Time (Assume Fully Exhausted NiCd Battery)

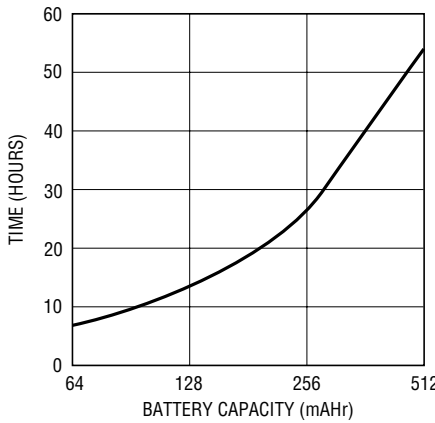

1558 G07

RESET Output Voltage vs Supply Voltage

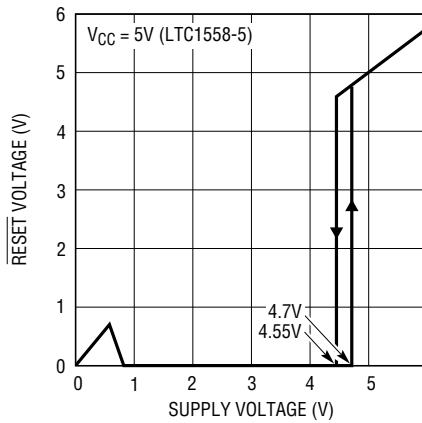

1558 G08

RESET Output Voltage vs Supply Voltage

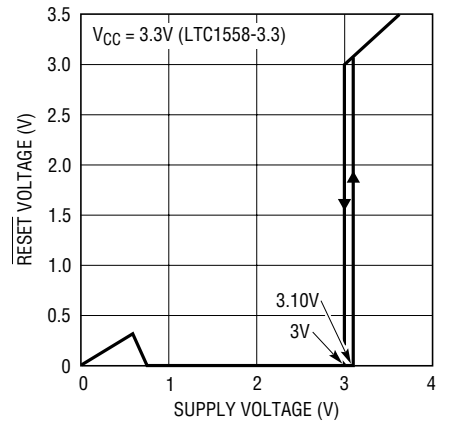

1558 G09

PIN FUNCTIONS

Pin Numbers are Shown First for the SO-8 Package Then the GN16 and S16 Packages

SW (Pins 1/1, 2): Boost Converter Switching Node. Connect a 22 μ H inductor from SW to the positive terminal of the backup cell. In backup mode, this node is alternately switched between ground and V_{BAK} , generating the backup output voltage. In fast or trickle charge mode, an internal regulator outputs a constant DC current from this pin through the 22 μ H inductor and into the NiCd battery. During power-up or undervoltage lockout (UVLO), the SW pin enters a high impedance state.

GND (Pins 2/4): System Ground. The low power internal circuitry returns to this pin in the 16-pin packages. GND and PGND are bonded together to this pin in the SO-8.

CTL (Pins 3/5): Control. This pin provides three functions. In backup mode this pin enters a high impedance state and monitors the backup battery cell voltage (V_{BAT}). If V_{BAT} drops below 0.9V, the LTC1558 enters into UVLO. During trickle charge mode, an external resistor R_{EXT} sets the trickle charge current. In all modes, pulling the CTL pin below 250mV will generate either a “soft” or “hard” reset pulse. See the Applications Information section for more information.

FB (Pins 4/7): Output Voltage Feedback. This pin is fed to the LTC1558’s internal comparators. The boost converter’s output voltage is set with an external resistor divider connected from V_{BAK} to FB. The LTC1558 enters backup mode when FB drops 7.5% below the internal reference voltage (V_{REF}). During backup, the boost converter runs whenever FB drops below this ($V_{\text{REF}} - 7.5\%$) threshold. The LTC1558 exits backup mode when FB rises above ($V_{\text{REF}} - 6\%$).

RESET (Pins 5/11): System Reset, Active Low. This is an open-drain output. This pin provides a low going reset signal to the system processor. A 200ms pulse is generated if the CTL pin is pulled low for more than two seconds (“hard” reset) or when the LTC1558 comes out of UVLO. The “hard reset” stops the internal boost converter if it is running. This pin is held low whenever the LTC1558 is in UVLO and is guaranteed to be valid when V_{CC} is greater than or equal to 1V.

RESET also provides a low going 100 μ s signal if the CTL pin is pulled low for less than two seconds (“soft” reset). Unlike hard reset, soft reset does not affect the LTC1558’s current operating mode.

BACKUP (Pins 6/13): Backup Active. This is an open-drain output that pulls low unless the LTC1558 is in backup mode. BACKUP signals the system controller that the system is in backup mode so that it can reduce system loading. BACKUP can also be used to drive the gate of a P-channel MOSFET in series with the main system regulator’s input. A 12V Zener diode is connected internally to this pin to act as a voltage clamp. See the Applications Information section for more details.

V_{CC} (Pins 7/14): Power Supply Input. All internal circuits except the boost converter are powered from this pin. A 0.1 μ F bypass capacitor is required from V_{CC} to ground. The UVLO detector inside the LTC1558 monitors V_{CC} . If V_{CC} drops below the rated output voltage by greater than 9%, the LTC1558 enters UVLO mode and RESET is asserted. The LTC1558 will only exit from UVLO if V_{CC} rises to greater than -6% of the rated output voltage. See the Applications Information section for more details.

V_{BAK} (Pins 8/15,16): Backup Supply Output. The LTC1558’s boost converter provides regulated output voltage to the system through V_{BAK} during backup mode.

16-Pin GN and SO Package

PGND (Pin 3): Power Ground. The internal driver circuitry returns to this pin. PGND should be connected to a low impedance ground plane in close proximity to the NiCd battery cell.

SHDN (Pin 6): Chip Shutdown. A TTL-compatible active low voltage at SHDN puts the LTC1558 into low power shutdown mode. In shutdown, all internal circuits power down and are held in a reset state. The SW, CTL and V_{BAK} pins enter into high impedance states. In shutdown mode, supply current drops to below 50 μ A and current drawn from the backup cell drops to below 15 μ A.

PIN FUNCTIONS

LOBAT (Pin 9): Low-Battery Detector Output. This is an open-drain output that pulls low when the backup cell drops below 1V. It gives early warning to the system controller that the backup cell is getting weak. This pin is disabled when the LTC1558 is in trickle charge mode.

RESET (Pin 12): System Reset, Active High. This is a TTL-compatible output driver. It can be used to connect to systems that require active high logic. The RESET output will go high whenever RESET is pulled low. If RESET is externally pulled low, RESET will go high.

BLOCK DIAGRAM

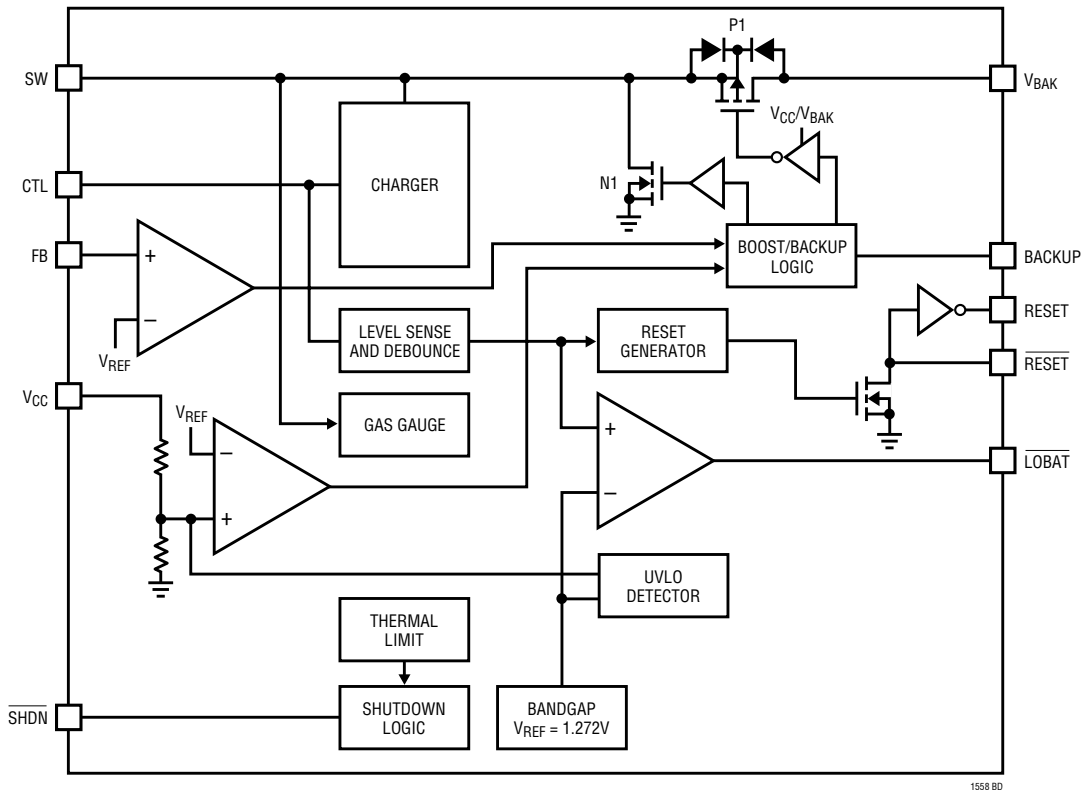

SWITCHING WAVEFORMS

Simplified LTC1558 Connections in a Battery Backup System

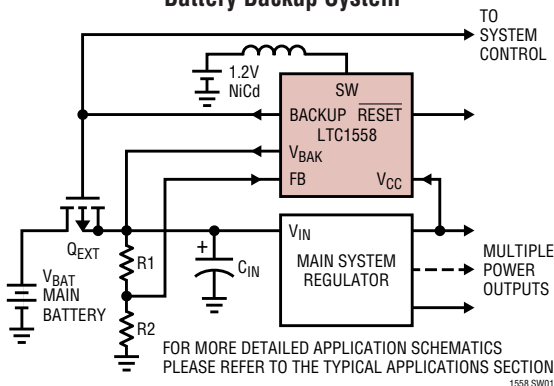

Cold Power Boot-Up (Main Battery Replaced/Turned On)

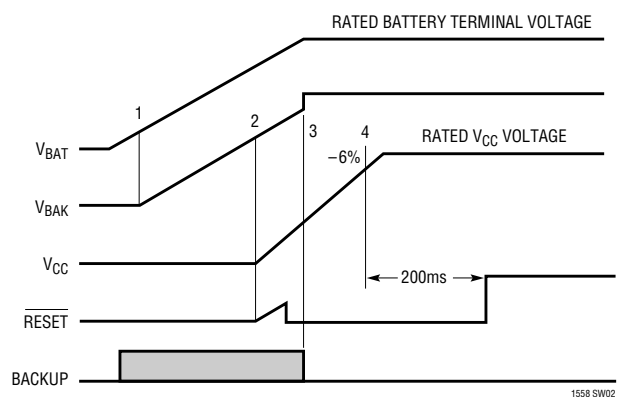

SWITCHING WAVEFORMS

Cold Power Boot-Up Description

1. The V_{BAT} voltage increases and turns on the Q_{EXT} body diode. V_{BAK} follows V_{BAT} by one body diode drop.
2. V_{BAK} increases above the system regulator's minimum input voltage. The system regulator wakes up and starts ramping up the system power supply. \overline{RESET} remains asserted from $V_{CC} = 1V$.
3. The LTC1558's internal bandgap wakes up. The LTC1558's internal boost converter does not turn on as \overline{RESET} remains asserted. Once V_{FB} is greater than $(V_{REF} - 6\%)$, \overline{BACKUP} is deasserted after the t_{PHL} delay time. Q_{EXT} turns on and $V_{BAK} = V_{BAT}$.
4. \overline{RESET} is asserted for a further 200ms after V_{CC} exceeds -6% of its rated value.

Backup Mode (Main Battery Discharged)

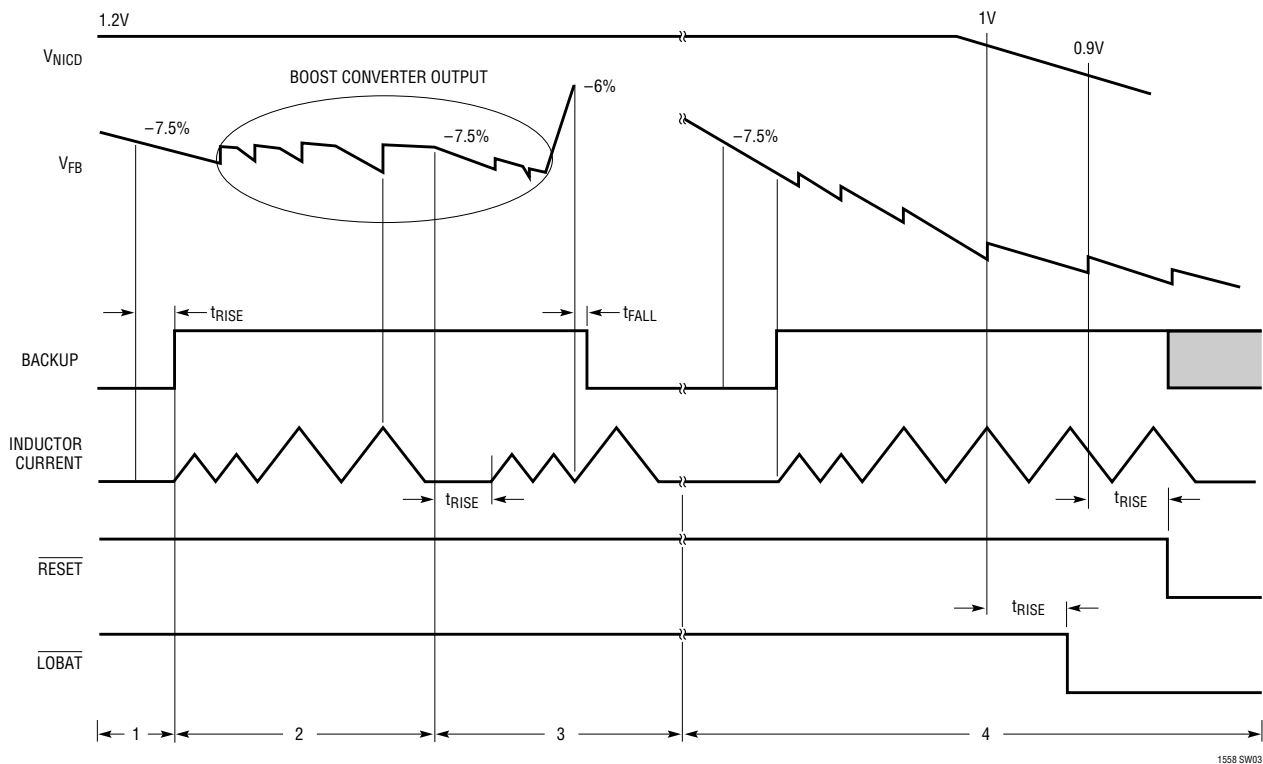

Backup Mode Description

1. Trigger into Backup Mode. The main battery fails and V_{FB} drops 7.5% below the LTC1558's internal V_{REF} . The \overline{BACKUP} pin is asserted after a t_{RISE} delay time and the LTC1558's boost converter is turned on.
2. Backup Mode. The LTC1558's boost converter charges and discharges the inductor with 165mA peak current. If V_{FB} doesn't recover above $(V_{REF} - 7.5\%)$ (due to a heavy load), the boost converter increases peak charging current to 330mA. When V_{FB} rises above $(V_{REF} - 7.5\%)$, the boost converter stops but the \overline{BACKUP} pin remains asserted.
3. Recovery from Backup Mode. While the boost converter is running, the main battery is restored. This causes the external MOSFET's body diode to conduct and V_{FB} is pulled higher than $(V_{REF} - 6\%)$. \overline{BACKUP} deasserts and the boost converter finishes its last cycle.
4. Trigger into UVLO. During backup, the 1.2V NiCd cell grows weak and its terminal voltage falls. The \overline{LOBAT} pin is asserted to give an early warning when the cell voltage drops below 1V. \overline{RESET} is asserted when the cell voltage drops below 0.9V and the LTC1558 enters UVLO mode.

APPLICATIONS INFORMATION

Overview

The LTC1558 is a versatile backup battery control system designed to provide all the functions necessary to implement a complete, highly integrated backup system within a single chip. It allows the system to maintain its rated supply voltage during backup, offering maximum system design flexibility. The LTC1558 allows the use of a low cost rechargeable NiCd cell for backup, eliminating the need for expensive, replaceable 4.5V lithium backup cells.

The LTC1558 includes an onboard boost converter designed to generate an adjustable voltage (3V to 10V) from a single 1.2V NiCd cell. This voltage is connected to the system's DC/DC converter input, enabling the system to continue operation when the main battery fails. A "smart" recharging circuit uses an accumulating gas gauge to measure the charge extracted from the backup battery during a backup cycle. This measured charge is then replaced in a fast recharge cycle, without wasting excess power or overcharging the backup cell. An externally adjustable trickle charge circuit maintains the cell charge after the fast charge cycle has completed, minimizing drain from the main battery during standby.

Included in the LTC1558 is a complete backup circuit that monitors the main system power and automatically switches in the backup circuit as the primary power supply falls away (due to a weak or disconnected main battery). The LTC1558 also performs V_{CC} supervisory functions during normal system operations. An LTC1558-3.3 monitors a 3.3V supply voltage at its V_{CC} pin whereas an LTC1558-5 monitors a 5V supply at its V_{CC} pin. In both cases, the LTC1558 derives power for the majority of the internal circuitry (except for the boost converter) from the V_{CC} pin. Table 1 shows the signal conditions for the LTC1558's various operating modes. Note that V_{CC} in Table 1 refers to the rated V_{CC} voltage, 3.3V or 5V.

Boost Converter Operation

The LTC1558 uses an onboard synchronous boost converter with a fixed peak current architecture that provides a simple and flexible system solution while eliminating the need for conventional frequency compensation. The boost converter's output, set by the external divider connected to the FB pin, supports the main system regulator during

Table 1

OPERATING MODES	CONDITIONS
UVLO Reset	$1V < V_{CC} < V_{CC} \text{ (Rated Value)} - 9\%$ or $V_{BAT} < 0.9V$
Pushbutton Reset	$V_{CTL} < 250mV$
UVLO Reset Recovery	$V_{CC} > V_{CC} \text{ (Rated Value)} - 6\%$
Backup Mode Activation	$V_{FB} < (V_{REF} - 7.5\%)$
Backup Mode Exit	$V_{FB} > (V_{REF} - 6\%)$
Boost Converter Activation	$V_{FB} < (V_{REF} - 7.5\%)$
Boost Converter Deactivation	$V_{FB} > (V_{REF} - 7.5\%)$

backup. It can supply a minimum backup power of 100mW. The boost converter operates in a modified pulse skipping mode; each switch cycle transfers a known amount of charge from the backup cell to the regulated output. This prevents uncontrolled discharge of the backup cell and allows the LTC1558 to accurately measure the charge removed from the backup cell by counting the charge pulses.

The LTC1558 enters backup mode when the main battery voltage drops. As shown in Figure 1, the main battery voltage is scaled down by an external resistor divider and fed to the LTC1558's backup comparators. These compare the scaled voltage with an internal trimmed V_{REF} (1.272V), switching the LTC1558 into backup mode when V_{FB} drops 7.5% below V_{REF} . Upon entering backup mode, the BACKUP pin is asserted and the internal boost converter turns on. The BACKUP signal is used to turn off the external P-channel MOSFET, isolating the main battery from the LTC1558 and the system regulator's input. The LTC1558's boost converter will charge the input capacitor C_{IN} of the system regulator until V_{FB} rises above $(V_{REF} - 7.5\%)$.

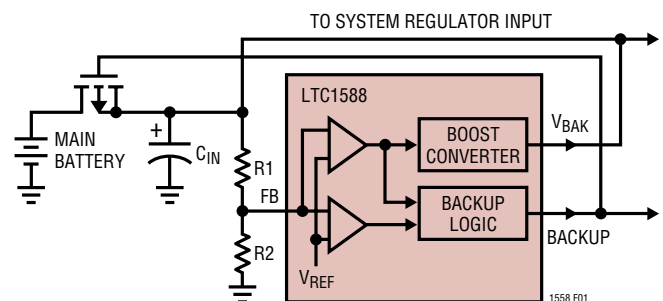

Figure 1. Typical LTC1558 Connection

APPLICATIONS INFORMATION

Once V_{FB} rises above $(V_{REF} - 7.5\%)$, the LTC1558's boost converter deactivates and the freshly charged input capacitor supplies power to the system regulator. The cycle repeats again when the input capacitor's charge is drained away and V_{FB} again drops below $(V_{REF} - 7.5\%)$. The BACKUP pin remains asserted until the main battery is restored. This ensures that the LTC1558 does not switch in and out of backup mode unnecessarily.

The LTC1558's boost converter minimizes output ripple under light load conditions by reducing the charge transferred for the first two consecutive switch cycles. When V_{FB} falls below $(V_{REF} - 7.5\%)$, the boost operation starts by connecting the SW pin to ground through an internal 0.5Ω N-channel MOSFET (N1 in the Block Diagram). The current through the external $22\mu\text{H}$ inductor rises linearly through this switch.

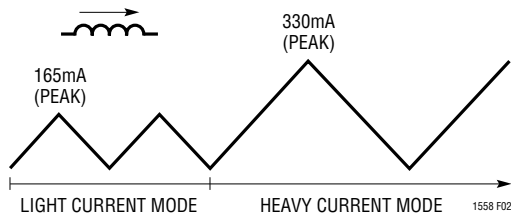

Figure 2. Inductor Current During Switching

When the switch current reaches an internally preset level of 165mA, the boost converter connects the SW pin to the V_{BAK} pin through an internal 2Ω P-channel MOSFET (P1 in the Block Diagram). The inductor current discharges through P1, charging up the capacitor connected externally to V_{BAK} (C_{IN} of the system regulator, Figure 1). The inductor current falls at a rate proportional to the difference between the backup cell voltage and the output voltage V_{BAK} . When the inductor current reaches zero, indicating all of its energy has been transferred to the output capacitor, the LTC1558 looks at the FB pin voltage. If V_{FB} has increased above the $(V_{REF} - 7.5\%)$ threshold, the boost converter shuts off both switches and waits for V_{FB} to drop below $(V_{REF} - 7.5\%)$ again.

If V_{FB} is still less than $(V_{REF} - 7.5\%)$ after the first boost cycle, the LTC1558 immediately reconnects SW to ground, repeating the boost cycle. If after two consecutive pulses, V_{FB} is still not above the boost threshold $(V_{REF} - 7.5\%)$, the LTC1558 decides that the load is not so light after all,

and doubles the internal inductor charging current limit to 330mA for subsequent cycles. This is high current mode. By doubling the peak inductor current, each boost cycle effectively carries four times more energy compared to low current mode ($E = 1/2 \cdot LI^2$), doubling the available output power. When V_{FB} exceeds the $(V_{REF} - 7.5\%)$ boost threshold, the LTC1558 stops the boost converter and resets the internal two pulse counter. The next time V_{FB} falls below $(V_{REF} - 7.5\%)$, the boost converter restarts in low current mode for at least two boost cycles. Moderate or changing loads will cause the LTC1558 to shift between the two peak inductor current limits, keeping the output in tight regulation. Near its maximum load capability, the LTC1558 will stay in 330mA high current mode and the output voltage V_{BAK} will hover around the user programmed value.

V_{BAK} Capacitor ESR

The type of output capacitor and the user programmed V_{BAK} value will affect the LTC1558's output ripple and efficiency. In most applications, the main V_{BAK} capacitor is primarily determined by the requirements of the main power supply. Such a capacitor will generally meet the requirements of the LTC1558. In unusual circumstances or circuits where the main system regulator's input capacitor is located some distance away from the LTC1558, a local output capacitor may be necessary.

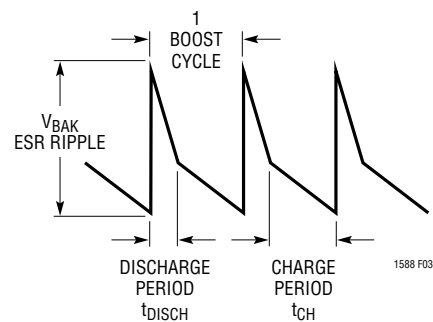

Figure 3. V_{BAK} Ripple

The maximum ripple on the V_{BAK} pin is equal to capacitor ESR voltage drop due to the boost converter's output current pulses. The ripple frequency and output duty cycle is proportional to the inductor discharge time. Given a fixed inductor value ($22\mu\text{H}$) and a known peak current limit, the booster's discharge time in each boost cycle is

APPLICATIONS INFORMATION

proportional to the difference between V_{BAK} (3V to 10V) and the battery cell voltage, V_{BAT} (1.2V).

Assuming $\text{ESR} = 0.2\Omega$, $I_{\text{IND(PEAK)}} = 330\text{mA}$, $V_{\text{BAK}} = 6\text{V}$,

$$\begin{aligned} V_{\text{RIPPLE(P-P)}} &= (I_{\text{IND(PEAK)}})(R_{\text{ESR(CAP)}}) \\ &= (330\text{mA})(0.2\Omega) \\ &= 66\text{mV} \end{aligned}$$

Since V_{BAK} must be scaled down to V_{FB} , the external resistor ratio

$$\begin{aligned} &= 6\text{V}/1.272\text{V} \\ &= 4.717 \end{aligned}$$

Therefore the noise amplitude seen by the FB comparators is:

$$\begin{aligned} &= 66\text{mV}/4.717 \\ &= 14\text{mV} \end{aligned}$$

The discharge time period,

$$\begin{aligned} t_{\text{DISCH}} &= (L \cdot I_{\text{IND(PEAK)}})/(V_{\text{BAK}} - V_{\text{BAT}}) \\ &= (22\mu\text{H} \cdot 330\text{mA})/(6\text{V} - 1.2\text{V}) \\ &= 1.5\mu\text{s} \end{aligned}$$

For lowest $V_{\text{BAK}} = 3\text{V}$ and maximum $I_{\text{IND(PEAK)}} = 445\text{mA}$,

$$\begin{aligned} V_{\text{RIPPLE(P-P)}} &= 89\text{mV} \\ \text{RB resistor ratio} &= 2.358 \\ \text{Noise amplitude} &= 37.7\text{mV} \\ t_{\text{DISCH}} &= 5\mu\text{s} \end{aligned}$$

The internal V_{FB} comparators are designed to have a slow response time to filter away this ripple. The ($V_{\text{REF}} - 6\%$) FB comparator has a $6\mu\text{s}$ rising edge delay and $2\mu\text{s}$ falling edge delay. The ($V_{\text{REF}} - 7.5\%$) FB comparator has a similar $6\mu\text{s}$ rising time delay but a much longer falling time delay of $20\mu\text{s}$. This enables the comparator to control the booster properly, and avoids turning off the boost converter prematurely due to false triggering by the ESR ripple.

Exit from Backup

When a new battery is inserted into the system, the higher main battery voltage turns on the external P-channel MOSFET's body diode and raises V_{BAK} (and V_{FB}) to a higher voltage. The LTC1558 detects the return of the main

battery by watching for V_{FB} to exceed ($V_{\text{REF}} - 6\%$). The LTC1558 then stops its internal boost converter and begins to recharge the NiCd cell. BACKUP is deasserted to signal to the system controller to restore system loading and resume normal operations. At the same time, the external P-channel MOSFET is driven by the BACKUP signal. The P-channel MOSFET turns on and allows the main battery to bypass its body diode and drive the system regulator directly.

Since the user can replace the main battery anytime during the LTC1558's backup operations, the BACKUP signal may be deasserted while the boost converter is switching. To prevent the potential problem of residual energy in the inductor, the LTC1558 will only stop the boost converter after it has completed the current boost cycle.

UVLO Lockout Under Excessive Backup Load

Very heavy loads (above the LTC1558's maximum power output) will pull the boost converter's output below the boost threshold. Under these conditions, the LTC1558's boost converter will continue to supply 330mA current pulses to the system regulator while charge on the V_{BAK} capacitor (C_{IN}) drains away. The system regulator will not maintain its output regulation and the system V_{CC} will drop. When V_{CC} drops below -9% of the rated voltage for more than $9\mu\text{s}$, the LTC1558's V_{CC} supervisory circuit activates UVLO mode, shutting off the boost converter and asserting the RESET pins. The $9\mu\text{s}$ delay prevents the LTC1558 from being fooled by brief transients or noise spikes on its V_{CC} pin. Upon receipt of the reset signals, the host system should shut down in an orderly manner. The LTC1558's V_{CC} supervisory circuit will remain alive until V_{CC} is less than 1V to ensure valid reset pin signals.

Backup Cell Voltage Monitoring

As the boost converter removes charge from the backup NiCd cell, the cell's terminal voltage falls. Permanent damage to the NiCd cell can occur if it is discharged to below 0.9V. To prevent this, the LTC1558 monitors the cell's terminal voltage through the CTL pin during backup. If the CTL pin drops below 0.9V for more than $20\mu\text{s}$, the UVLO circuit shuts down the boost converter and asserts the RESET pins. Since the CTL pin can also be connected to an external pushbutton reset, the LTC1558 includes

APPLICATIONS INFORMATION

internal logic to ensure that the low cell voltage reset is triggered only if the CTL pin is between 0.9V and 0.25V. This will prevent a pushbutton reset (which pulls CTL below 250mV) from being mistaken as a low cell voltage condition. Unusual situations where the NiCd cell voltage drops drastically below 0.25V will also trigger UVLO, since the LTC1558 will treat this as a “hard” reset after 2 seconds.

An optional $\overline{\text{LOBAT}}$ output, available in the 16-pin GN or SO package, can be used to signal the system when the cell voltage falls below 1V, giving an early warning that the backup cell is heavily discharged. The $\overline{\text{LOBAT}}$ output is disabled when the LTC1558 is in trickle charge mode because the CTL pin is pulled to 0.5V by the LTC1558.

Fault Protection and Thermal Limit

The LTC1558’s boost converter incorporates two internal timers that turn off the switch transistors if the inductor charge or discharge time gets abnormally long.

The inductor charge time may get abnormally long if the NiCd cell voltage drops below 0.25V without triggering the $0.25\text{V} < V_{\text{BAT}} < 0.9\text{V}$ low cell voltage comparator. In this case, the NiCd cell is assumed to be damaged and the LTC1558’s priority is shutting down the system gracefully. In this case, the timer will shut off the N-channel switch transistor after a maximum charging time (14 μs). The boost converter continues switching but delivers reduced output power, causing V_{CC} to drop. The LTC1558 will enter UVLO either when V_{CC} drops below ($V_{\text{CC(RATED VOLTAGE)}} - 9\%$) or after the LTC1558 detects CTL lower than 0.25V for 2 seconds, in which case “hard” reset occurs.

The discharging time can also get abnormally long if a serious overload condition occurs during switching. The timer will shut off the P-channel pass transistor after 10 μs , protecting the boost converter. The LTC1558 will end up in UVLO as V_{CC} drops below ($V_{\text{CC(RATED VOLTAGE)}} - 9\%$).

In addition, the LTC1558 is protected for safe area operation with an internal thermal shutdown circuit. If the device is overloaded for a long period of time, the thermal shutdown circuit forces the LTC1558 into UVLO. The threshold temperature for thermal shutdown is typically 155°C.

The LTC1558’s boost converter is designed so that no current drains from the battery to the load during output short circuit or $V_{\text{CC}} = 0\text{V}$ conditions. This assures that the system can be powered down for a long period of time. This eliminates the risk of finding a nonfunctioning backup system upon power-up.

Backup Cell Fast Recharge

The LTC1558 includes an onboard gas gauge circuit, consisting of a 23-bit divider and a 9-bit up/down counter. The gas gauge logic assumes that the boost converter uses a 22 μH inductor, allowing it to estimate battery charge by counting switch pulses. The gas gauge counts up from zero as charge is removed from the backup cell in backup mode. It takes roughly 8.4 million 165mA boost pulses (low current mode) to increment the up/down counter by one count. In high current mode, the 330mA pulses skip the first two bits of the divider because each 330mA pulse carries four times as much energy as a 165mA pulse. At maximum load and $V_{\text{CC}} = 5\text{V}$, the gas gauge divider will increment by one count every 7.5 μs while the boost converter is running. Full count is reached after approximately 2.2 hours, equivalent to about 512mAh of charge.

Upon entering recharge mode (after the main battery is restored) the LTC1558 connects a 16mA fast recharge current source from V_{CC} to the SW pin. At the same time, an internal free running oscillator counts down the gas gauge counter at a rate designed to replace about 160% of the charge previously removed from the backup cell. When the gas gauge counter reaches zero, the LTC1558 reduces the charging current at the SW pin to the user-programmed trickle charge current level.

Under some circumstances, the LTC1558 can exit the backup mode with invalid gas gauge contents. This can occur under three possible conditions:

- The backup cell was completely exhausted during a backup cycle and the LTC1558 entered UVLO.
- The backup cell was replaced while the main supply was disabled.
- A backup cycle was terminated prematurely by a “hard” reset or an output overload.

APPLICATIONS INFORMATION

In these cases, the LTC1558 assumes that the backup cell is exhausted and presets the gas gauge counter to a default capacity of 128mAh. It then initiates a recharge cycle.

Setting the gas gauge to this default value results in a fast recharge cycle long enough to replenish 1.6 times 128mAh of charge into the backup cell (13.9 hours). If the backup cell is actually exhausted, it will be fully recharged. If the battery is partially or fully charged, or is significantly smaller than 128mAh capacity, the extra charging time will be wasted. However, the LTC1558's 15mA fast charge current should not be high enough to damage the cell. Once the full-count recharge has been completed, the backup cell is assumed to be fully charged and subsequent backup/recharge cycles resume normally.

Although the LTC1558 will not fully recharge backup cells larger than 128mAh capacity upon power-up, it can still be used with such cells. Such a cell will be fully replenished by the subsequent trickle charge cycle. Under most conditions, even a partially charged large cell will still be capable of supporting several hours of backup. For example, a small 60mAh button cell can back up the system for 20 minutes at an output power of 100mW. Note that at lower programmed V_{BAK} values, the boost converter efficiency improves and allows more backup time from the same cell compared to a higher V_{BAK} value.

Once it reaches full recharge, a cell bigger than 512mAh is likely to overrun the gas gauge counter before it runs out of charge during an extended backup cycle. The LTC1558 gas gauge counter will not roll over if this occurs; it will stay at full count until the backup cycle ends and then partially recharge the cell with a full count cycle as above.

Very short backup cycles (<32s) may not extract enough charge from the backup cell to increment the gas gauge counter at all. To ensure that the backup cell is not slowly "nibbled" away, the gas gauge counter is always incremented by 1mAh each time the controller comes out of backup. This ensures that the backup cell is always replenished with at least a 1mAh charge every time the LTC1558 enters backup mode.

Battery Backup Cell Trickle Charge

When the gas gauge counter reaches zero, the LTC1558 terminates fast recharge and reduces the recharge current to the user-programmed trickle current level. The LTC1558 provides a trickle current that the user can program from 50 μ A to 2mA. The trickle current is set by an external resistor from the positive terminal of the backup cell to the CTL pin. In trickle charge mode, CTL is regulated to 0.5V, resulting in a CTL pin current of $(V_{\text{BAT}} - 0.5)/R_{\text{EXT}}$. This current is internally multiplied to feed back ten times the R_{EXT} current into the backup battery. Since the LTC1558 trickle charges only after the completion of the fast recharge cycle, the backup cell voltage should be very close to 1.2V. This simplifies the calculation of the R_{EXT} resistor value. For example, a 47k resistor from V_{BAT} to CTL sets the trickle charge current to approximately 150 μ A.

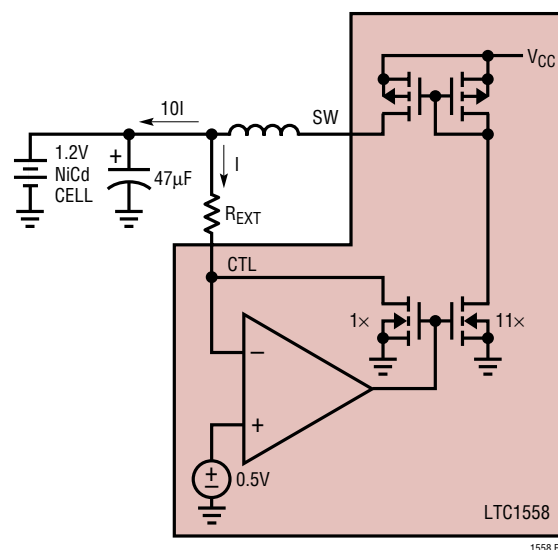

Figure 4. Trickle Current Charger

Undervoltage Lockout

The LTC1558 includes an undervoltage lockout (UVLO) system that ensures that the system will shutdown gracefully if the backup cell is exhausted or overloaded. As described in the previous section, the LTC1558 will

APPLICATIONS INFORMATION

terminate backup operation and remain off until the main power supply returns. It then runs a fast recharge cycle to recharge the backup cell. An onboard low-battery comparator in the 16-pin GN or SO package provides an early warning signal when the backup cell drops below 1V.

The UVLO circuit also trips if the LTC1558's V_{CC} supervisory circuit detects that V_{CC} drops below -9% of the rated V_{CC} voltage due to overload or output short-circuit conditions. Once the UVLO circuit trips, the LTC1558 asserts the RESET pins until the V_{CC} voltage drops below 1V. It will then remain off until V_{CC} rises to within $(V_{CC} - 6\%)$ of the rated output voltage. During power-up from UVLO, the LTC1558 asserts the RESET pins until the $(V_{CC} - 6\%)$ threshold. Once V_{CC} exceeds $(V_{CC} - 6\%)$, the RESET pins remain asserted for another 200ms ("hard" reset) before being released to inform the system to start operating.

Reset Operation

The LTC1558 includes an onboard pushbutton reset switch controller. If the CTL pin is pulled to ground ($< 250\text{mV}$) by a pushbutton or an open-drain output, the LTC1558 generates a pulse at the RESET pins after the trailing edge of

the CTL signal. A short (less than 2s) low going signal at CTL will generate a "soft" reset (100 μs) pulse at the RESET pins. A low CTL signal for more than 2s will generate a "hard" reset pulse at its RESET pins. During "hard" reset, the LTC1558 will disable the boost converter if it is in backup mode. All signals at the CTL pin are debounced for 20ms to prevent multiple resets, allowing the CTL pin to be connected directly to a pushbutton to ground.

The $\overline{\text{RESET}}$ pin is an open-drain output that requires an external pull-up resistor. The RESET pin is a TTL-compatible CMOS output.

Shutdown

The 16-pin LTC1558 has a TTL-compatible input, $\overline{\text{SHDN}}$, that shuts down the whole chip, asserts the RESET pins and places the CTL, V_{BAK} and SW pins into high impedance states. The SHDN pin has an internal pull-up that ensures the chip will not shut down if the pin is left floating. The SHDN pin typically draws 8 μA when pulled low at $V_{CC} = 5\text{V}$. The chip consumes less than 50 μA during shutdown while V_{CC} is still alive.

Although there is no SHDN pin for the SO-8 package, the user can shut down the part by pulling CTL to ground. The chip enters "hard" reset leaving only the bandgap and comparators alive. The charger and the boost converter shut off completely. Note that the backup cell slowly discharges through R_{EXT} in this mode.

Inductor Selection

The LTC1558 is designed to operate with a recommended inductor value of 22 μH ($\pm 20\%$) with $< 0.2\Omega$ DC resistance.

Using inductor values higher than 22 μH will deliver more output power but will cause the gas gauge counter to count inaccurately and under recharge the backup cell. At the same time, the N-channel transistor timer will limit the peak current if the charging time becomes overextended due to the higher inductor value. Using inductor values lower than 22 μH will degrade the boost converter's maximum output power and cause the gas gauge counter to overcharge the backup cell. Table 2 lists the recommended surface mount inductor part numbers.

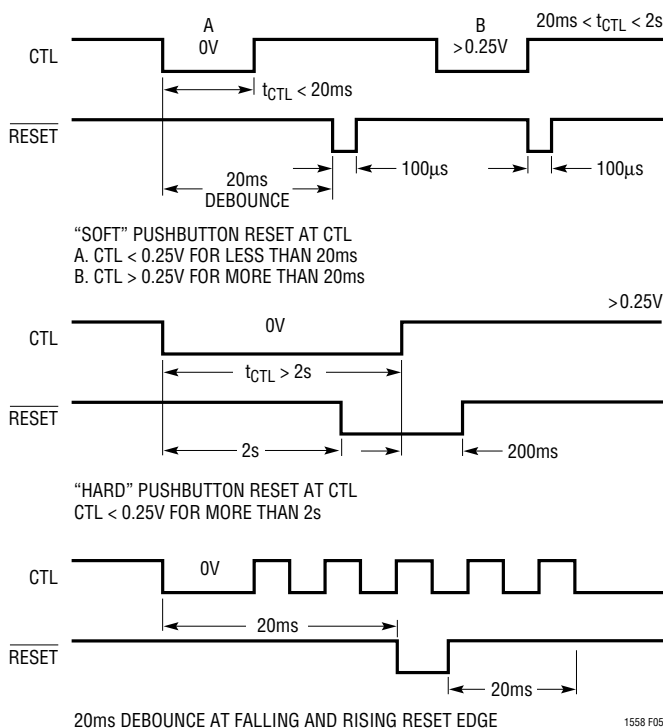

Figure 5. Pushbutton Resets

APPLICATIONS INFORMATION

Table 2. Recommended Inductors

MANUFACTURER	PART NUMBER	TYP INDUCTOR VALUE	DCR (Ω)
Sumida	CD54-220	22 μ H \pm 20%	0.18
Sumida	CDRH73/74	22 μ H \pm 20%	0.2/0.11

Capacitor Selection

The LTC1558 requires a minimum V_{BAK} capacitor of 44 μ F to ensure that the boost converter can regulate the output at 20mA load. The capacitor's ESR should be small ($< 0.2\Omega$) to minimize voltage spikes that might incorrectly trigger the LTC1558's internal FB comparators. Note that the LTC1558 can usually share the output capacitor with the system regulator. Thus its ratings like V_{MAX} , $I_{RIPPLE(RMS)}$, etc., will all have to meet the system regulator's specifications as well.

Battery Selection

A primary application for the LTC1558 is a "bridging" supply, only providing backup current while the main system battery is being replaced. In these applications, the LTC1558 works well with NiCd button cells or small cylindrical cells, reducing system costs and board space. It is optimized for use with up to 512mAh battery capacities.

The LTC1558 can work with standard or memory backup specific NiCd cells. Memory backup cells can operate at higher temperatures and have lower self discharge rates. The LTC1558's trickle charger is designed to accommodate both memory backup cells (with low self discharge) and standard cells (with higher self discharge). Some recommended manufacturers and part numbers are listed in Table 3.

Table 3. Button/Cylindrical NiCd 1.2V Cells

MANUFACTURER	PART NUMBER	CAPACITY (mAh)	R _{SERIES} (Ω)
SAFT (Memory Backup)	GB60	60	1.1
	GB170	170	0.4
	GB280	280	0.4
SAFT (Standard)	VB10E	100	0.038
	VB22E	220	0.022
	VB30E	300	0.017
	VB60E	600	0.014
Sanyo (Standard)	N-50AAA	55	0.055
	N-110AA	120	0.03
	N-120TA	130	0.034
	N-150N	170	0.027
	N-200AAA	220	0.021
	N-270AA	305	0.015
	N-500A	500	0.09
Panasonic (Standard)	P-11AA	110	0.08

The internal resistance of the backup cell increases power dissipation as the boost converter draws current from it during switching, degrading efficiency. Due to the fixed inductor peak current architecture, the LTC1558's boost converter output power drops significantly when the NiCd cell's internal resistance increases at the end of its charge. This is because the inductor charging time will increase due to a larger R/L time constant, decreasing the switching frequency. It is advisable, especially for batteries with high internal resistance, to include a 47 μ F bypass capacitor across the battery to ensure that the boost converter can deliver the maximum output power regardless of the NiCd internal resistance.

TYPICAL APPLICATIONS

LTC1558-3.3 Low Main Battery Voltage (4.5V to 10V) Application

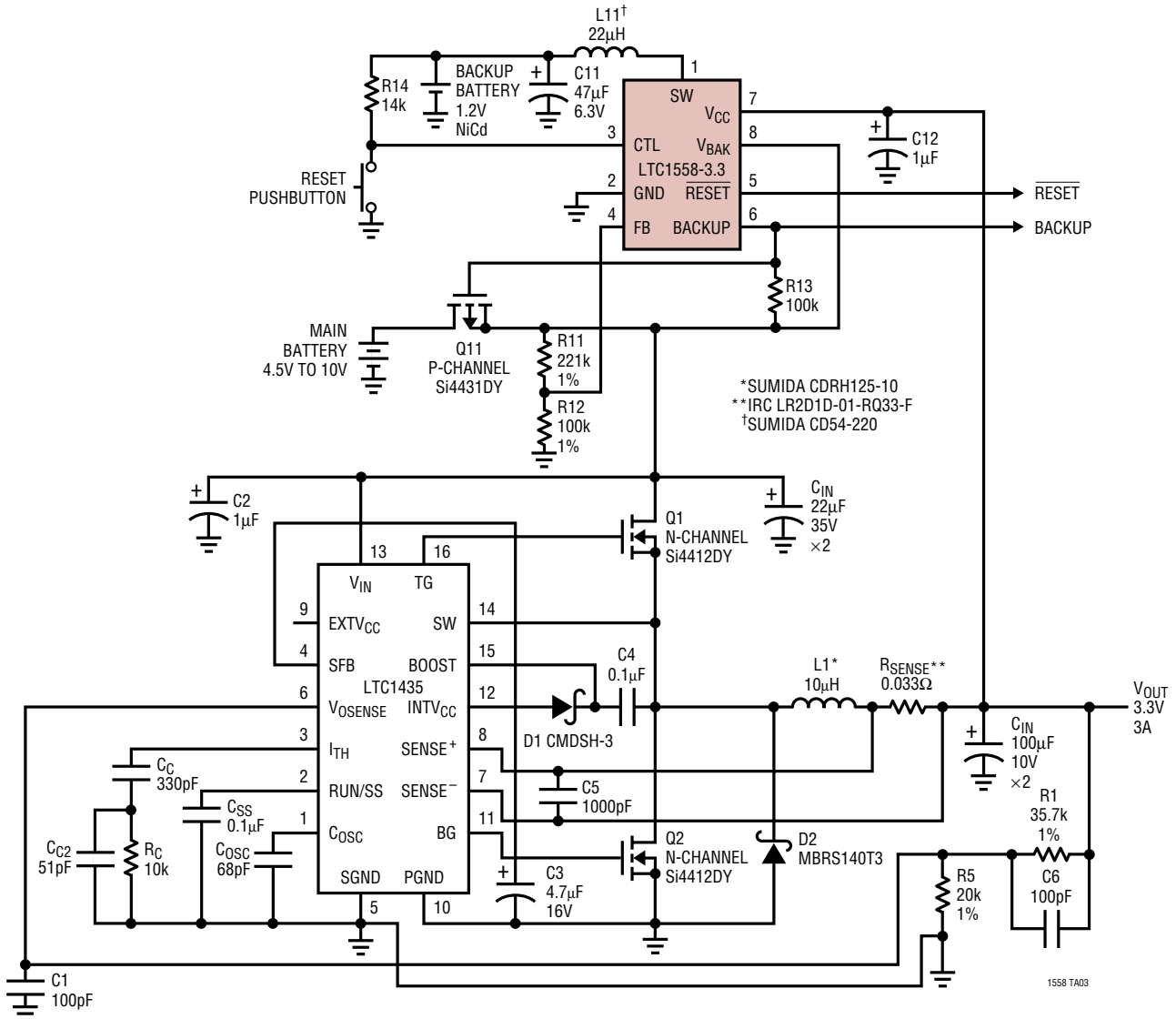

Typical “Low Voltage” Application

The maximum main battery voltage is less than the maximum V_{BAK} pin voltage (12V). This configuration has the lowest number of external components.

The LTC1435’s minimum input voltage is 3.5V. The V_{BAK} voltage, set by R11 and R12, is programmed to 3.8V. Therefore, the main battery’s lowest voltage should be $3.8V + 1$ body diode drop = 4.5V. This will enable a fresh

main battery to turn on the external P-channel MOSFET and power up the system out of UVLO during cold power boot or out of backup mode when the LTC1558 is powering up the system.

A 100k pull-up resistor enables the open-drain BACKUP pin to turn the external P-channel MOSFET off when V_{BAK} is higher than V_{CC} .

TYPICAL APPLICATIONS

LTC1558-5 Medium Main Battery Voltage (7V to 18V) Application

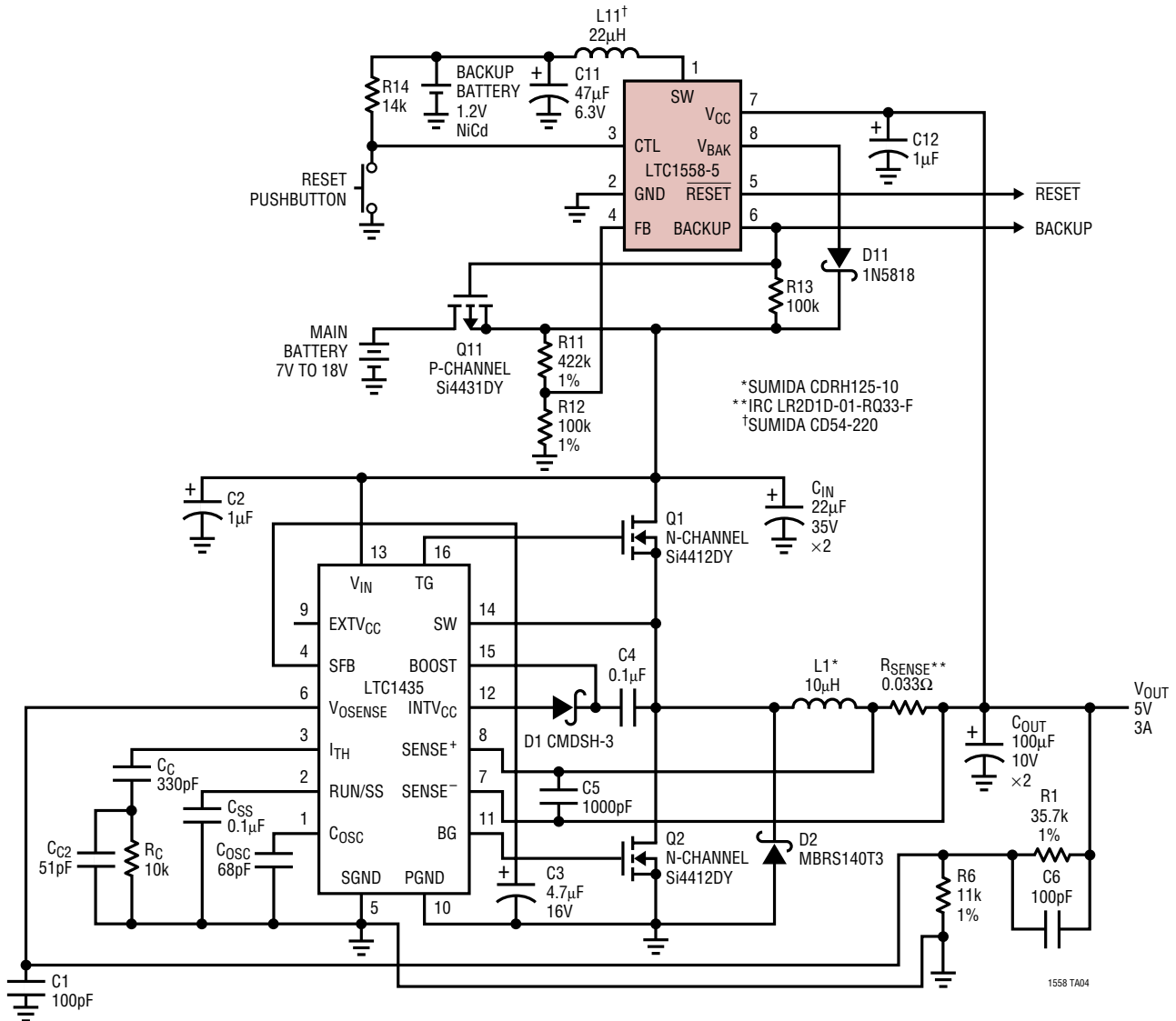

Typical “Medium Voltage” Application

The maximum main battery voltage is more than the maximum V_{BAK} pin voltage (12V). This configuration is needed for most notebook computers that have 3-cell or 4-cell series connected lithium battery packs.

The Schottky diode D11 (1N5818) prevents the main battery’s high terminal voltage from overstressing the LTC1558’s V_{BAK} pin during nonbackup conditions. An internal Zener inside the LTC1558 will clamp V_{BAK} to 12V when the 1N5818’s reverse bias leakage current increases at high temperature.

A 100k pull-up resistor enables the LTC1558’s open-drain BACKUP pin to turn the external P-channel MOSFET off during backup mode, even when V_{BAK} is higher than V_{CC} .

The main battery pack should have an internal control to shut itself down once its energy is used up. This prevents the lithium cells from deep discharge damage. Once the main battery shuts down, the FB voltage drops and the LTC1558 switches to backup mode.

TYPICAL APPLICATIONS

LTC1558-5 High Main Battery Voltage (48V) Application

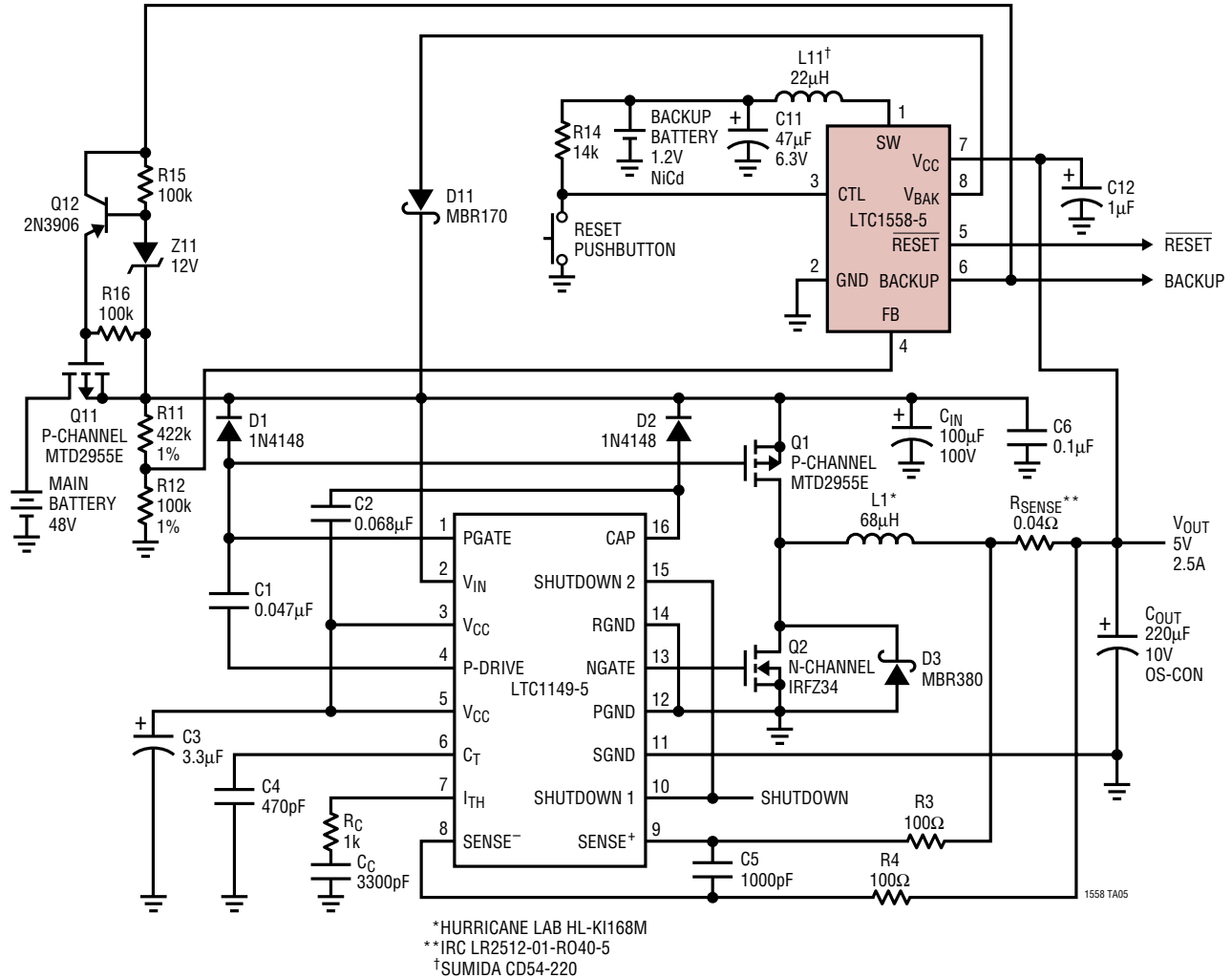

Typical “High Voltage” Application

The maximum main battery voltage is 48V.

The Schottky diode D11 (MBR170) prevents the main battery’s high terminal voltage from overstressing the LTC1558’s V_{BAK} pin during nonbackup conditions. An internal Zener inside the LTC1558 will clamp V_{BAK} to 12V when the MBR170’s reverse bias leakage current increases at high temperature.

As shown above, the design must ensure that V_{BAT} does not force the external P-channel MOSFET’s V_{GS} above its maximum rating (15V for the MTD2955E) shown during nonbackup mode.

During nonbackup mode, the LTC1558’s open-drain BACKUP pin is low. The external 12V Zener and 2N3906 conduct and the MTD2955E’s V_{GS} is clamped at approximately 12V. During backup, the BACKUP pin floats and the 2N3906’s base voltage is pushed nearer to V_{BAK} . The MTD2955E is effectively turned off, isolating the main battery from V_{BAK} during backup.

The main battery pack should have an internal control to shut itself down once its energy is used up. This prevents it from deep discharge damage.

PACKAGE DESCRIPTION Dimensions in inches (millimeters) unless otherwise noted.

GN Package
16-Lead Plastic SSOP (Narrow 0.150)
 (LTC DWG # 05-08-1641)

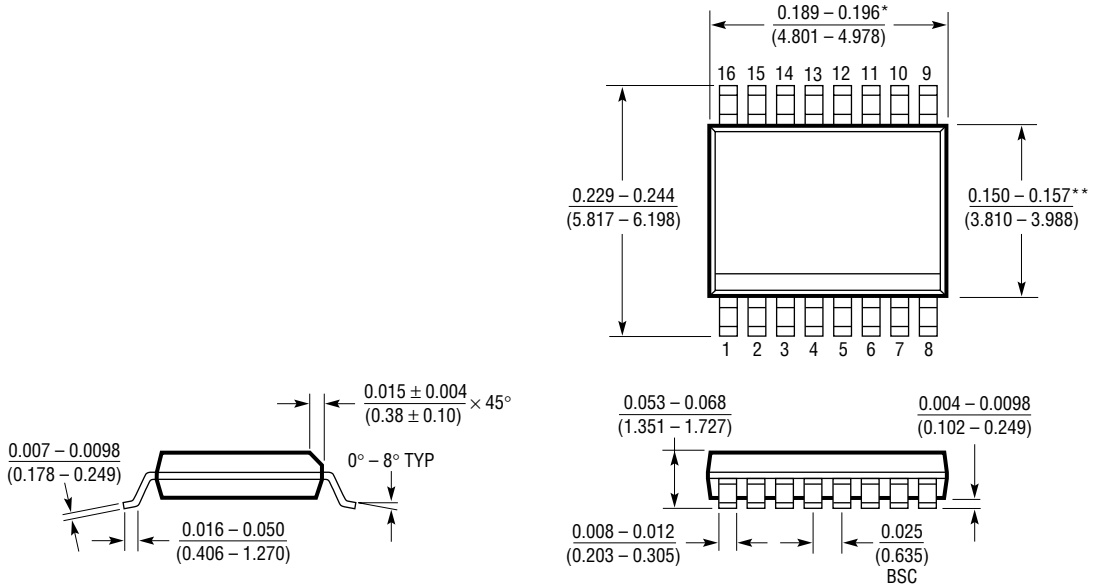

- * DIMENSION DOES NOT INCLUDE MOLD FLASH. MOLD FLASH SHALL NOT EXCEED 0.006" (0.152mm) PER SIDE
- ** DIMENSION DOES NOT INCLUDE INTERLEAD FLASH. INTERLEAD FLASH SHALL NOT EXCEED 0.010" (0.254mm) PER SIDE

GN16 (SSOP) 1197

PACKAGE DESCRIPTION Dimensions in inches (millimeters) unless otherwise noted.

S8 Package
8-Lead Plastic Small Outline (Narrow 0.150)
 (LTC DWG # 05-08-1610)

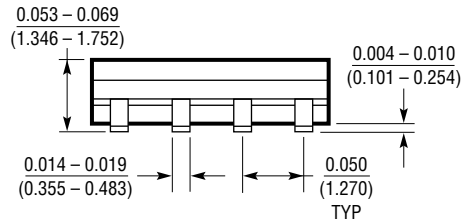
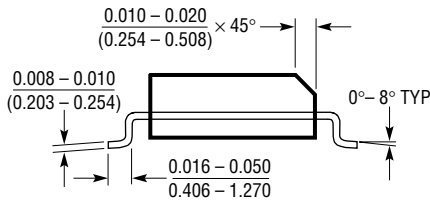
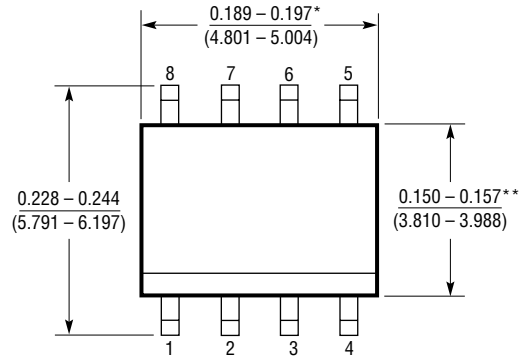

* DIMENSION DOES NOT INCLUDE MOLD FLASH. MOLD FLASH SHALL NOT EXCEED 0.006" (0.152mm) PER SIDE
 ** DIMENSION DOES NOT INCLUDE INTERLEAD FLASH. INTERLEAD FLASH SHALL NOT EXCEED 0.010" (0.254mm) PER SIDE

S08 0996

S Package
16-Lead Plastic Small Outline (Narrow 0.150)
 (LTC DWG # 05-08-1610)

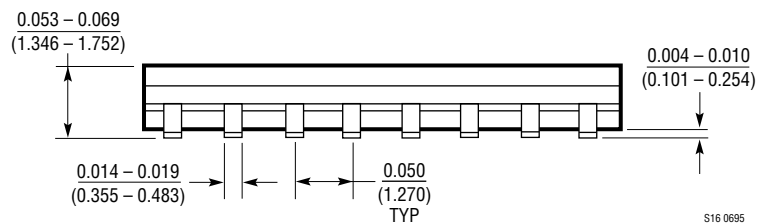
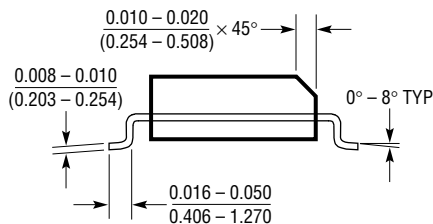
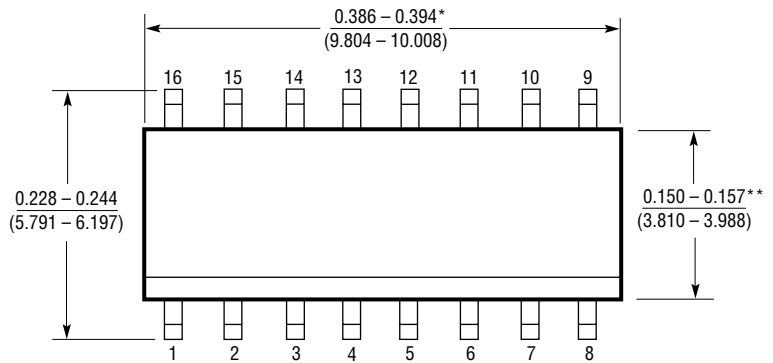

* DIMENSION DOES NOT INCLUDE MOLD FLASH. MOLD FLASH SHALL NOT EXCEED 0.006" (0.152mm) PER SIDE
 ** DIMENSION DOES NOT INCLUDE INTERLEAD FLASH. INTERLEAD FLASH SHALL NOT EXCEED 0.010" (0.254mm) PER SIDE

S16 0695

RELATED PARTS

PART NUMBER	DESCRIPTION	COMMENTS
LTC690/LTC691 LTC694/LTC695	Microprocessor Supervisory Circuits	Microprocessor Power Supply Monitor and Backup with Power Fail Comparator
LT [®] 1020	Micropower Linear Regulator	Includes Low-Battery and Dropout Detectors
LT1120	Micropower Linear Regulator	SO-8 Package, Includes Low-Battery Detector
LTC1149	High Efficiency Synchronous Step-Down Switching Regulator	V _{IN} up to 48V, Burst Mode™ Operation
LTC1235	Microprocessor Supervisory Circuit	Includes Pushbutton Reset and Power Fail Comparator
LTC1435	High Efficiency, Low Noise Synchronous Step-Down Switching Regulator	Ultrahigh Efficiency, Burst Mode Operation
LTC1479	PowerPath™ Controller for Dual Battery Systems	Complete Power Management Controller for Battery Notebook Computers and Other Portable Equipment
LT1521	Micropower Low Dropout Regulator	300mA, SOT-223 Package

Burst Mode and PowerPath are trademarks of Linear Technology Corporation.